

Disc Mowers

DM36 Series

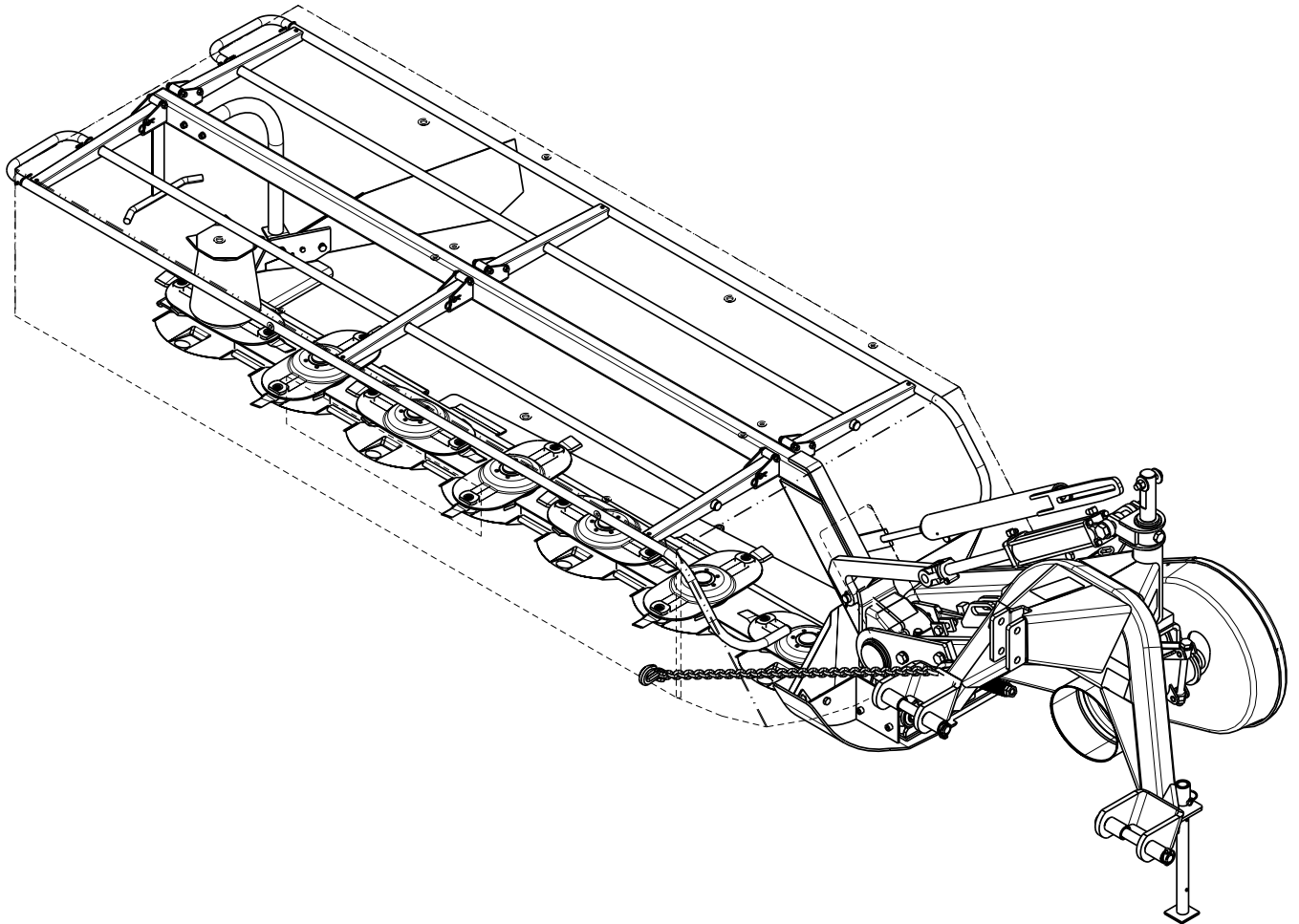

327-045M
Operator's Manual



Read the Operator's manual entirely. When you see this symbol, the subsequent instructions and warnings are serious - follow without exception. Your life and the lives of others depend on it!



© Copyright 2002

8/7/2002

Cover photo may show optional equipment not supplied with standard unit.

Table of Contents

Important Safety Information	1	Section 3 Adjustments	16
Be Aware of Signal Words	1	Transport Lock Operation	16
Safety Labels	4	Belt Tension Adjustment	17
Introduction	7	Cutting Height	17
Application	7	Section 4 Maintenance and Lubrication .18	
Using This Manual	7	General Maintenance	18
Terminology	7	At the beginning of each season	18
Definitions	7	Servicing Blades	18
Owner Assistance	7	Blade Replacement	18
Further Assistance	7	Fastener Replacement	18
Section 1 Assembly and Set-Up	8	Cutter Bar Timing Adjustment	19
Tools Required	8	Removal of disc shaft assemblies	19
Assembly Preparation	8	Storage	20
Cutter Bar and Gearbox Lubrication	8	Lubrication	21
Mainframe Assembly	8	Driveline	21
Belt Cover and Pulleys Assembly	10	Driveline U-Joints	21
Support Stand Assembly	10	Gearbox	21
Cutting Unit Assembly	11	Cutter Bar	22
Section 2 Operating	12	Frame Pivot Point	22
Attaching the Tractor	12	Hitch Pivot Point	22
Transporting	13	Section 5 Specifications and Capacities 23	
Operating Check List	13	Section 6 Features and Benefits	24
Working Position	14	Section 7 Troubleshooting	25
Mowing Instructions	14	Section 8 Appendix	26
Adverse Field Conditions	14	Torque Values Chart	26
Operating Instructions	15	Warranty	27

© Copyright 2002 All rights Reserved

Land Pride provides this publication "as is" without warranty of any kind, either expressed or implied. While every precaution has been taken in the preparation of this manual, Land Pride assumes no responsibility for errors or omissions. Neither is any liability assumed for damages resulting from the use of the information contained herein. Land Pride reserves the right to revise and improve its products as it sees fit. This publication describes the state of this product at the time of its publication, and may not reflect the product in the future.

Land Pride is a registered trademark.

All other brands and product names are trademarks or registered trademarks of their respective holders.

Printed in the United States of America.

Important Safety Information

These are common practices that may or may not be applicable to the products described in this manual.

Be Aware of Signal Words

A signal word designates a degree or level of hazard seriousness. The signal words are:

DANGER!

Indicates an imminently hazardous situation which, if not avoided, will result in death or serious injury. This signal word is limited to the most extreme situations, typically for machine components that, for functional purposes, cannot be guarded.

WARNING!

Indicates a potentially hazardous situation which, if not avoided, could result in death or serious injury, and includes hazards that are exposed when guards are removed. It may also be used to alert against unsafe practices.

CAUTION!

Indicates a potentially hazardous situation which, if not avoided, may result in minor or moderate injury. It may also be used to alert against unsafe practices.



Keep Riders Off Machinery

- ▲ Riders obstruct the operator's view, they could be struck by foreign objects or thrown from the machine.
- ▲ Never allow children to operate equipment.

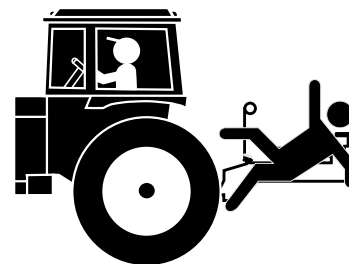

For Your Protection

- ▲ Thoroughly read and understand the "Safety Label" section, read all instructions noted on them.

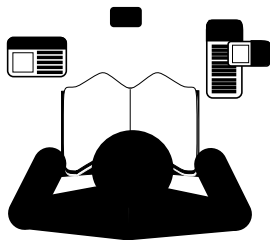

Shutdown and Storage

- ▲ Lower machine to ground, put tractor in park, turn off engine, and remove the key.
- ▲ Detach and store implements in a area where children normally do not play. Secure implement by using blocks and supports.

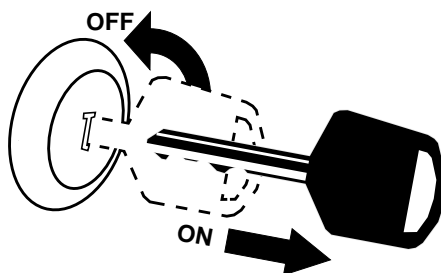

Important Safety Information

These are common practices that may or may not be applicable to the products described in this manual.

Use Safety Lights and Devices

- ▲ Slow moving tractors, self-propelled equipment, and towed implements can create a hazard when driven on public roads. They are difficult to see, especially at night.
- ▲ Flashing warning lights and turn signals are recommended whenever driving on public roads.

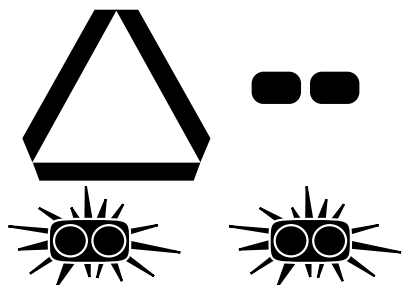

Transport Machinery Safely

- ▲ Comply with state and local laws.
- ▲ Maximum transport speed for implement is 20 mph. **DO NOT EXCEED.** Never travel at a speed which does not allow adequate control of steering and stopping. Some rough terrains require a slower speed.
- ▲ Sudden breaking can cause a towed load to swerve and upset. Reduce speed if towed load is not equipped with breaks.

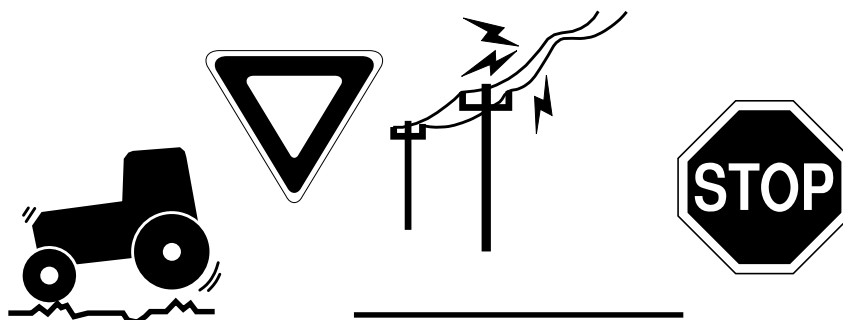

- ▲ Use the following maximum speed - tow load weight ratios as a guideline:
 - ▲ **20 mph** when weight is less than or equal to the weight of tractor.
 - ▲ **10 mph** when weight is double the weight of tractor.
 - ▲ **IMPORTANT:** Do not tow a load that is more than double the weight of tractor.

Practice Safe Maintenance

- ▲ Understand procedure before doing work. Use proper tools and equipment, refer to Operator's Manual for additional information.
- ▲ Work in a clean dry area.
- ▲ Lower the implement to the ground, put tractor in park, turn off engine, and remove key before performing maintenance.

- ▲ Allow implement to cool completely.
- ▲ Do not grease or oil implement while it is in operation.
- ▲ Inspect all parts. Make sure parts are in good condition & installed properly.
- ▲ Remove buildup of grease, oil or debris.
- ▲ Remove all tools and unused parts from implement before operation.



Tractors With Cabs Tractors Equipped With ROPS

- ▲ There should be sufficient clearance for the operator when mounted to a tractor with a cab or that is equipped with ROPS.
- ▲ The ROPS may need to be extended or flipped around to obtain sufficient clearance.

Important Safety Information

These are common practices that may or may not be applicable to the products described in this manual.

Prepare for Emergencies

- ▲ Be prepared if a fire starts.
- ▲ Keep a first aid kit and fire extinguisher handy.
- ▲ Keep emergency numbers for doctor, ambulance, hospital and fire department near phone.

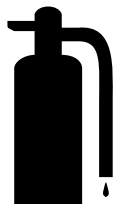
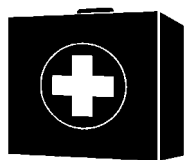

Wear Protective Equipment

- ▲ Protective clothing and equipment should be worn.
- ▲ Wear clothing and equipment appropriate for the job. Avoid loose fitting clothing.
- ▲ Prolonged exposure to loud noise can cause hearing impairment or hearing loss. Wear suitable hearing protection such as earmuffs or earplugs.
- ▲ Operating equipment safely requires the full attention of the operator. Avoid wearing radio headphones while operating machinery.



Tire Safety

- ▲ Tire changing can be dangerous and should be performed by trained personnel using the correct tools and equipment.
- ▲ When inflating tires, use a clip-on chuck and extension hose long enough to allow you to stand to one side and NOT in front of or over the tire assembly. Use a safety cage if available.
- ▲ When removing and installing wheels, use wheel handling equipment adequate for the weight involved.



Safety at All Times

Thoroughly read and understand the instructions given in this manual before operation. Refer to the "Safety Label" section, read all instructions noted on them.

- ▲ Operator should be familiar with all functions of the unit.
- ▲ Operate implement from the driver's seat only.
- ▲ Do not leave tractor or implement unattended with engine running.
- ▲ Dismounting from a moving tractor could cause serious injury or death.
- ▲ Do not stand between the tractor and implement during hitching.
- ▲ Keep hands, feet, and clothing away from power-driven parts.
- ▲ Wear snug fitting clothing to avoid entanglement with moving parts.
- ▲ Turning tractor too tight may cause implement to ride up on wheels. This could result in injury or equipment damage.

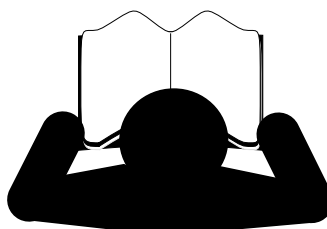

Important Safety Information

Safety Labels

Your Mower comes equipped with all safety labels in place. They were designed to help you safely operate your implement.

1. Read and follow label directions.
2. Keep all safety labels clean and legible.
3. Replace all damaged or missing labels.
4. Some new equipment installed during repair require safety labels to be affixed to the replaced component as specified by Land Pride. When ordering new components make sure

the correct safety labels are included in the request. To order new labels go to your Land Pride dealer.

5. Refer to this section for proper label placement. To install new labels:
 - a. Clean the area the label is to be placed.
 - b. Spray soapy water on the surface where the label is to be placed.
 - c. Peel backing from label. Press firmly onto the surface.
 - d. Squeeze out air bubbles with the edge of a credit card.

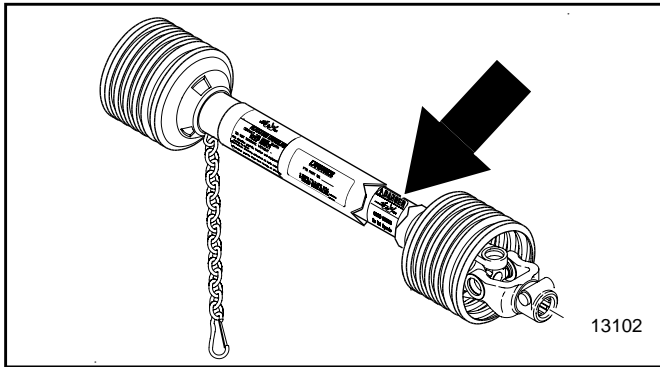

818-540C
Danger Guard Missing

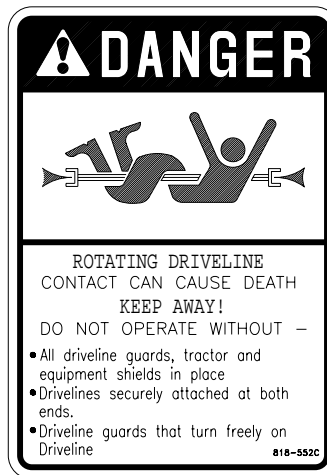
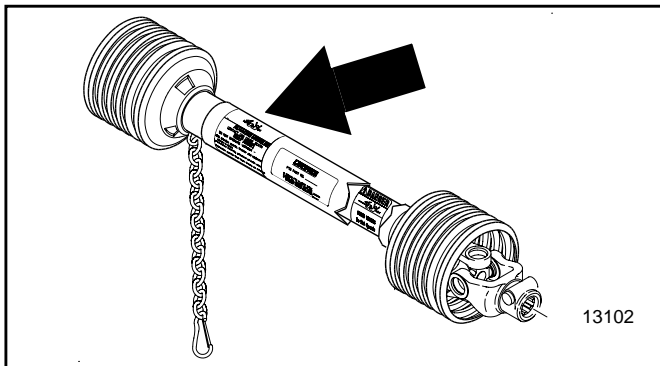

818-552C
Danger PTO Driveline

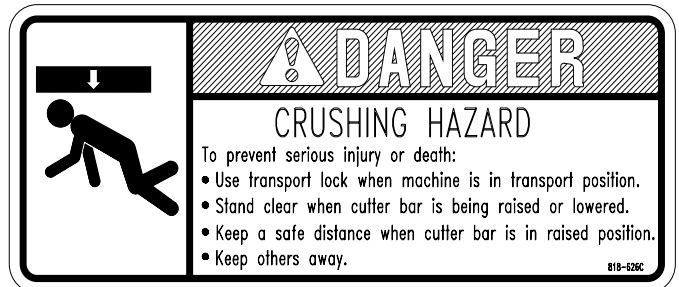
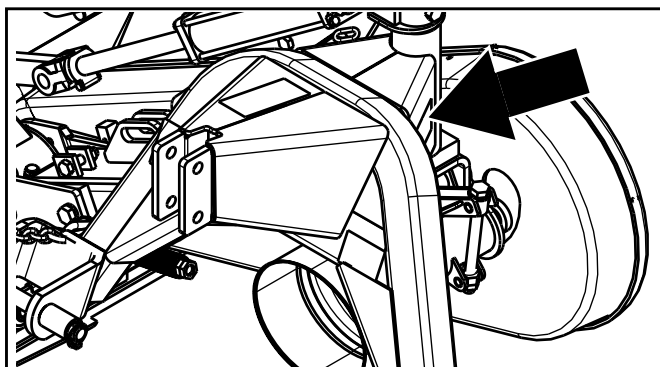

818-626C
Danger Crushing Hazard

Important Safety Information

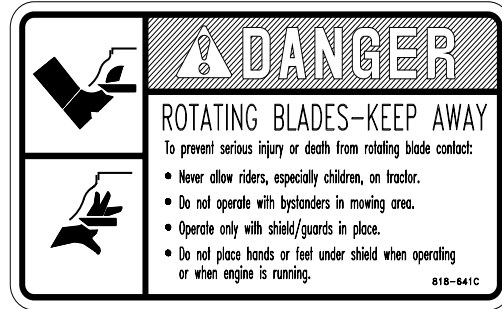
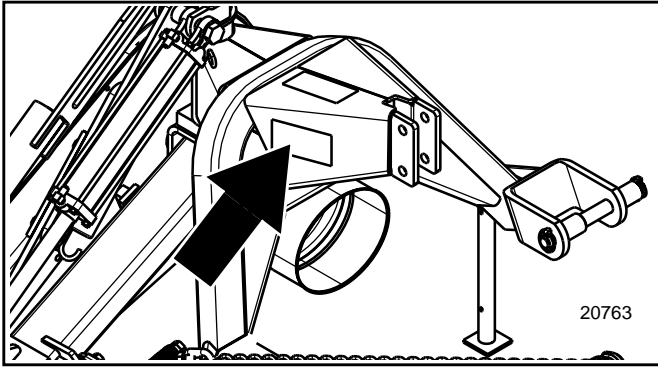

818-641C

Danger Rotating Blades

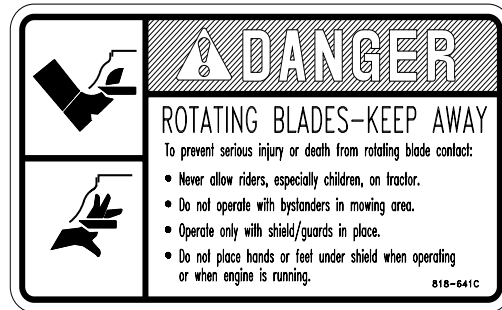
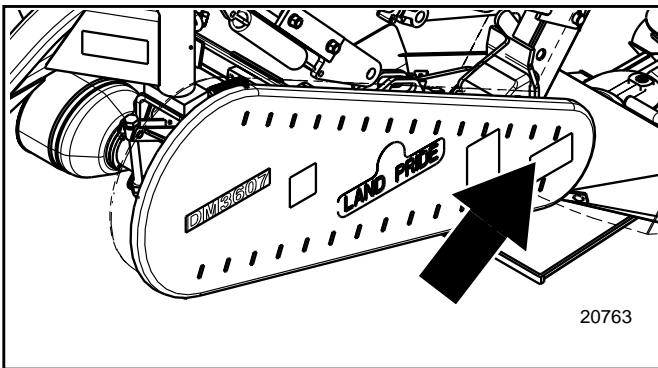

818-641C

Danger Rotating Blades

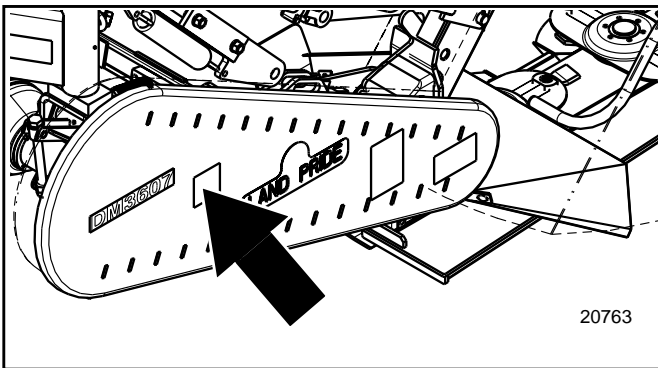

818-642C

Danger Thrown Object

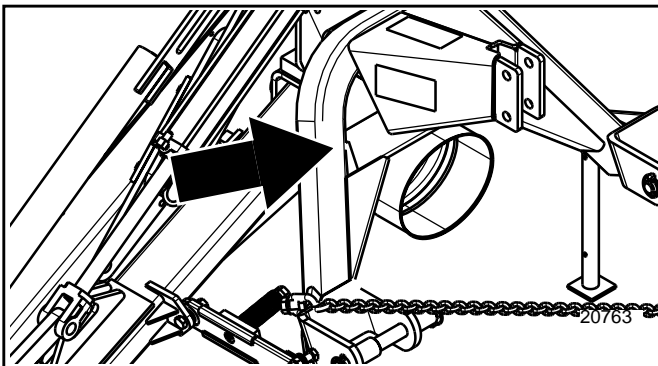

818-642C

Danger Thrown Object

Important Safety Information

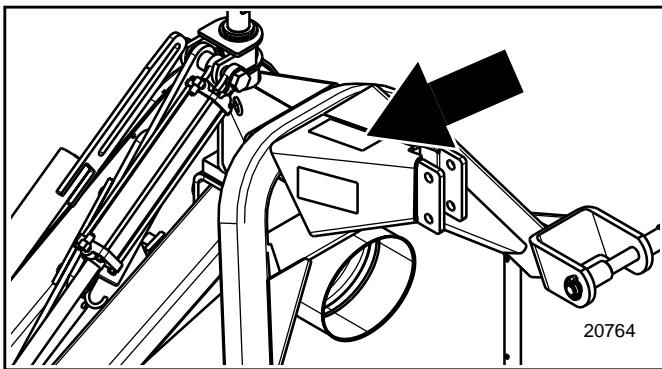

	! WARNING
	<p>HIGH PRESSURE FLUID HAZARD</p> <p>To prevent serious injury or death:</p> <ul style="list-style-type: none"> • Relieve pressure on system before repairing or adjusting or disconnecting. • Wear proper hand and eye protection when searching for leaks. Use wood or cardboard instead of hands. • Keep all components in good repair. <p style="text-align: right;"><small>838-094C</small></p>

838-094C

Warning: High Pressure

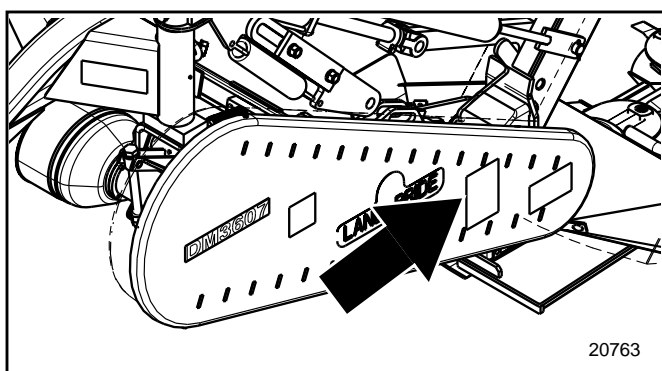

! WARNING
<p>To prevent serious injury or death:</p> <ul style="list-style-type: none"> • Read and understand Operator's manual before using. • Do not permit riders on the tractor or mower. Never carry child on tractor seat. • Operate with guards installed and in good condition. • Operate only with tractor equipped with ROPS and seatbelts. • Keep away from moving parts. • Stop engine, set brake and wait for all moving parts to stop before dismounting. • Be sure lights and reflectors required by law are clean and in good working order before transporting. • Do not allow children to operate mower. • Travel with SWV and lights that follow local codes. • Clean debris from mowing area. • Do not operate in the raised position. • Support securely before working beneath unit. • Review safety instructions annually. <p><i>Si no lee ingles, pida ayuda a alguien que si lea para que le traduzca las medidas de seguridad.</i></p> <p style="text-align: right;"><small>818-558C</small></p>

818-558C

Warning General Mower Safety

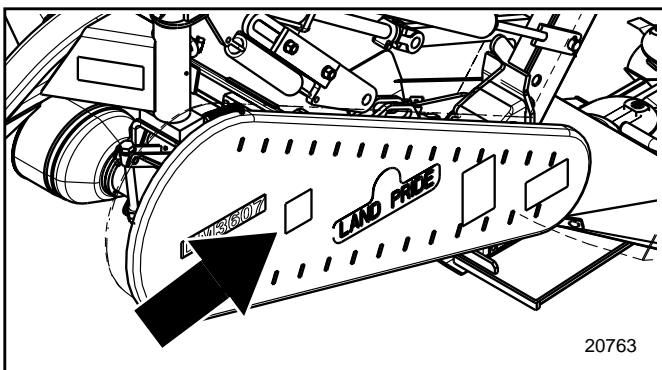

! DANGER
GUARD MISSING
When this is visible DO NOT OPERATE
ENTANGLEMENT HAZARD can cause Serious Injury or Death <i>Si no entiende ingles, se prefiere que busque a alguien que interprete las instrucciones para usted.</i>
<small>PHDC 6</small>

818-543C

Warning Guard Missing

Introduction

Land Pride welcomes you to the growing family of new product owners.

This Disc Mower has been designed with care and built by skilled workers using quality materials. Proper assembly, maintenance, and safe operating practices will help you get years of satisfactory use from the machine.

Application

The Land Pride Disc Mowers are designed and built to cut hay, grass, and other cultivated forage crops on farms, ranches, set-aside acres, and vast right-of-ways. They are adapted for 540 rpm three-point hitch Category II offset mounting and are Quick-Hitch adaptable. They are compatible with 35 HP to 80 HP tractors equipped with live or independent PTO's. The DM3605 has 5 discs and an 82" cutting width. The DM3606 has 6 discs and a 96" cutting width and the DM3607 has 7 discs and a 112" cutting width.

Land Pride Disc Mowers are designed to deliver good cutting performance even in thick, tangled, and wet grass conditions. Standard replaceable rock guards provide cutter bar protection in stony conditions and will greatly extend cutter bar life. A standard break-away latch will release, allowing the cutter bar to swing back, if an obstacle is hit.

Land Pride Disc Mowers are well suited for use in agricultural regions where humidity and moisture conditions are typically higher and the potential for crop entanglement and tough ground conditions are present. See "Features and Benefits", "Section 5" for additional information.

Using This Manual

- This Operator's Manual is designed to help familiarize you with safety, assembly, operation, adjustments, troubleshooting, and maintenance. Read this manual and follow the recommendations to help ensure safe and efficient operation.
- The information contained within this manual was current at the time of printing. Some parts may change slightly to assure you of the best performance.
- To order a new Operator's or Parts Manual contact your authorized dealer. Manuals can also be downloaded, free-of-charge from our website at www.landpride.com or printed from the Land Pride Service & Support Center by your dealer.

Terminology

"Right" or "Left" as used in this manual is determined by facing the direction the machine will operate while in use unless otherwise stated.

Definitions

NOTE: A special point of information that the operator must be aware of before continuing.

IMPORTANT: A special point of information related to its preceding topic. Land Pride's intention is that this information should be read and noted before continuing.

Owner Assistance

The Warranty Registration card should be filled out by the dealer at the time of purchase. This information is necessary to provide you with quality customer service.

If customer service or repair parts are required contact a Land Pride dealer. A dealer has trained personnel, repair parts and equipment needed to service the disc mower.

The parts on your disc mower have been specially designed and should only be replaced with genuine Land Pride parts. Therefore, should your disc mower require replacement parts go to your Land Pride Dealer.

Serial Number Plate

For prompt service always use the serial number and model number when ordering parts from your Land Pride dealer. Be sure to include your serial and model numbers in correspondence also. Refer to Figure 1 for the location of your serial number plate.

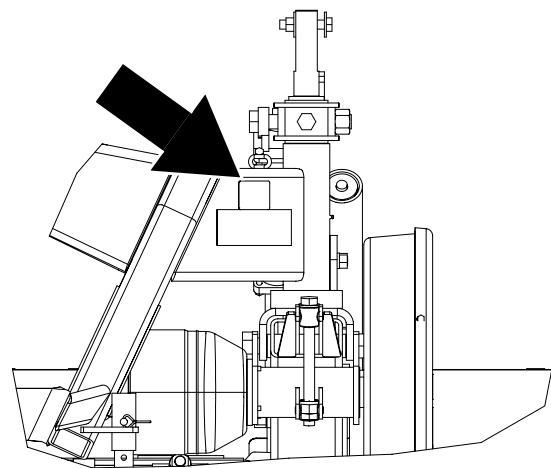

Serial Number Plate Location
Figure 1

20775

Further Assistance

Your dealer wants you to be satisfied with your new disc mower. If for any reason you do not understand any part of this manual or are not satisfied with the service received, the following actions are suggested:

1. Discuss the matter with your dealership service manager making sure he is aware of any problems you may have and that he has had the opportunity to assist you.
2. If you are still not satisfied, seek out the owner or general manager of the dealership, explain the problem and request assistance.
3. For further assistance write to:

Land Pride
Service Department
 P.O. Box 5060
 Salina, KS 67402-5060

Section 1 Assembly and Set-Up

Tools Required

- Fork lift, crane hoist or block-and-tackle
- Impact wrench or socket and ratchet set (metric)
- Rubber mallet
- Box-end (metric), allen (metric) and crescent wrenches
- Drift pins
- Screwdriver
- Safety shoes, safety glasses and gloves. A hard hat should be worn by anyone working under the crane.

Assembly Preparation

Having all the parts and equipment readily at hand will speed up your assembly task and make the job as safe as possible.

Prepare the area where the unit is to be assembled making sure the area is swept clean of all dust and contaminants. Un-package the crate and remove all contents carefully so that the seals on hydraulic components are not broken or pulled off.

NOTE: Remove heavy components from crate with a hoist or block-and-tackle.

Raise the mainframe with a forklift, hoist or block-and-tackle and place on pallets or blocks so it is elevated about 10" off the floor.

Your cutter bar will already be assembled. It is necessary to check the direction of rotation of each cutter plate. Figure 1-1 shows the proper cutter bar plate rotation. If adjustments need to be made, refer to "**Cutter Bar Timing Adjustment**" on page 19.

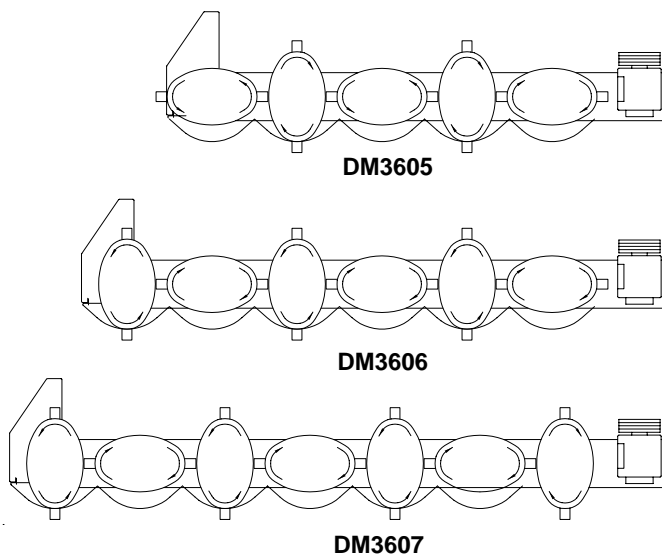

Cutter Bar Plate Rotation
Figure 1-1

15144

It is also necessary to check whether the plate turning right has right cutter blades and the plate turning left has left cutter blades.

Cutter Bar and Gearbox Lubrication

The cutter bar should arrive with oil already added. After assembly you may want to check to make sure. For instructions on how to do this see *Lubrication* in "**Section 4 Maintenance and Lubrication**" on page 18 and "**Section 5 Specifications and Capacities**" on page 23.

Before operating this unit add SAE 80 GL4 (EP) oil to gearbox. For further instructions see *Lubrication* in "Section 4 Maintenance and Lubrication" on page 18 and "Section 5 Specifications and Capacities" on page 23.

Mainframe Assembly

Refer to Figure 1-2:

1. Insert the gearbox on the cutter unit into the mainframe lug.
2. Assemble the gearbox pivot (#5) to the mainframe and gearbox as shown and secure with 3/4" bolts (#13) and lockwashers (#22).
3. Insert bushing (#2) into transport road latch (#1) and install on pin located on the cutting unit as shown.
4. Install spring mount (#10) as shown and secure with 3/4" bolt (#14) and lock nut.
5. Assemble spring cushion assembly (#4) to the mainframe as shown. Assemble the other end of the spring cushion assembly and hydraulic cylinder (#25) base end as shown using the long spacer (#9) and short spacer (#8). Secure with 1" bolt (#12) and lock nut (#18). Use one of the pins that comes with the cylinder to attach the lower end in slotted brackets.
6. Assemble spring assembly (#6) to the spring mount (#10) using 5/8" bolt (#15), flatwashers (#19) and lock nut (#17) to secure. Assemble the other end of spring assembly to the cutting unit with long bushing (#9) and cotter pin (#24).
7. Assemble cylinder extension arm (#7) to the hydraulic cylinder rod end. Assemble the other end to the same pin as the road latch (#1) and secure with cotter pin (#24).
8. Assemble breakaway assembly (#3) to the hitch with 5/8" nut (#16), lock washer (#21) and flat washer (#20) (spring facing inward).

Section 1 Assembly and Set-Up

Stroke Control for 3 Pt Disconnect:
When disconnecting unit from 3 Pt, lock channel (#11) and spring pin (#23) should be located between spring tube and rod stop. For running applications lock channel (#11) and spring pin (#23) should be stored below rod stop.

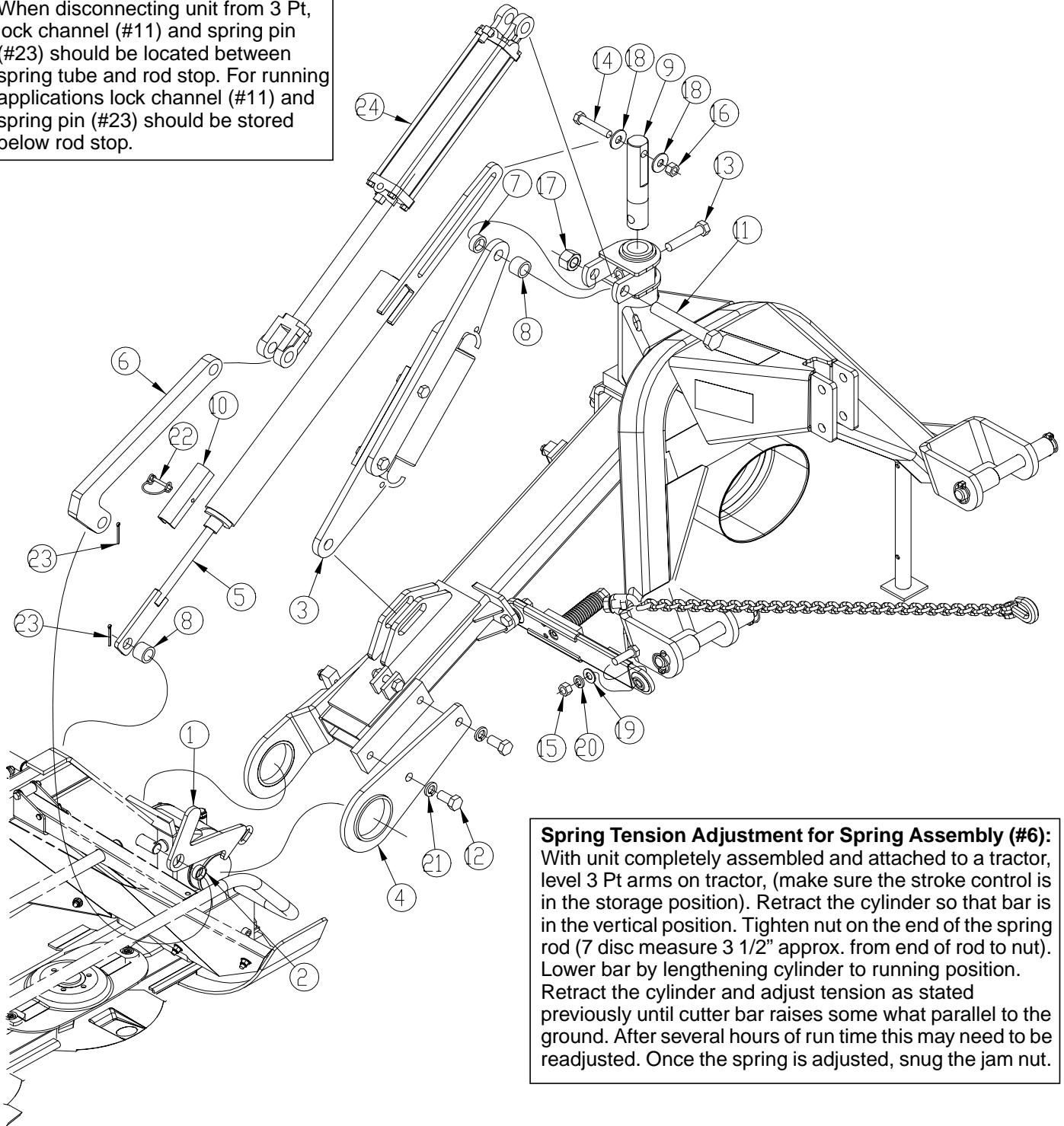

Spring Tension Adjustment for Spring Assembly (#6):
With unit completely assembled and attached to a tractor, level 3 Pt arms on tractor, (make sure the stroke control is in the storage position). Retract the cylinder so that bar is in the vertical position. Tighten nut on the end of the spring rod (7 disc measure 3 1/2" approx. from end of rod to nut). Lower bar by lengthening cylinder to running position. Retract the cylinder and adjust tension as stated previously until cutter bar raises somewhat parallel to the ground. After several hours of run time this may need to be readjusted. Once the spring is adjusted, snug the jam nut.

Main Frame Assembly
Figure 1-2

20768

Section 1 Assembly and Set-Up

Belt Cover and Pulleys Assembly

Refer to Figure 1-3:

1. Assemble the inner guard (#11) and the guard reinforcement (#1) to the disc mower with the 3/8" X 1" long bolts (#4) and flat washers (#6).
2. Install pulleys (#8) and (#9) as shown and secure with keys (#2).
3. Install belt (#10) to pulleys. Pulley (#8) may need to be adjusted so pulley can be assembled. Refer to "Belt Tension Adjustment" on page 17.

Support Stand Assembly

Refer to Figure 1-4:

Insert stand into tube on the hitch as shown and secure with pin and hair pin cotter.

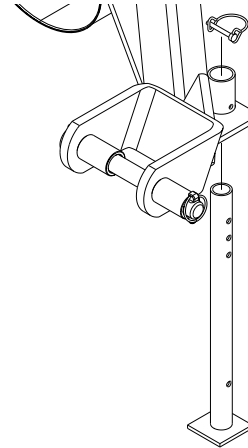

Support Stand
Figure 1-4

20765

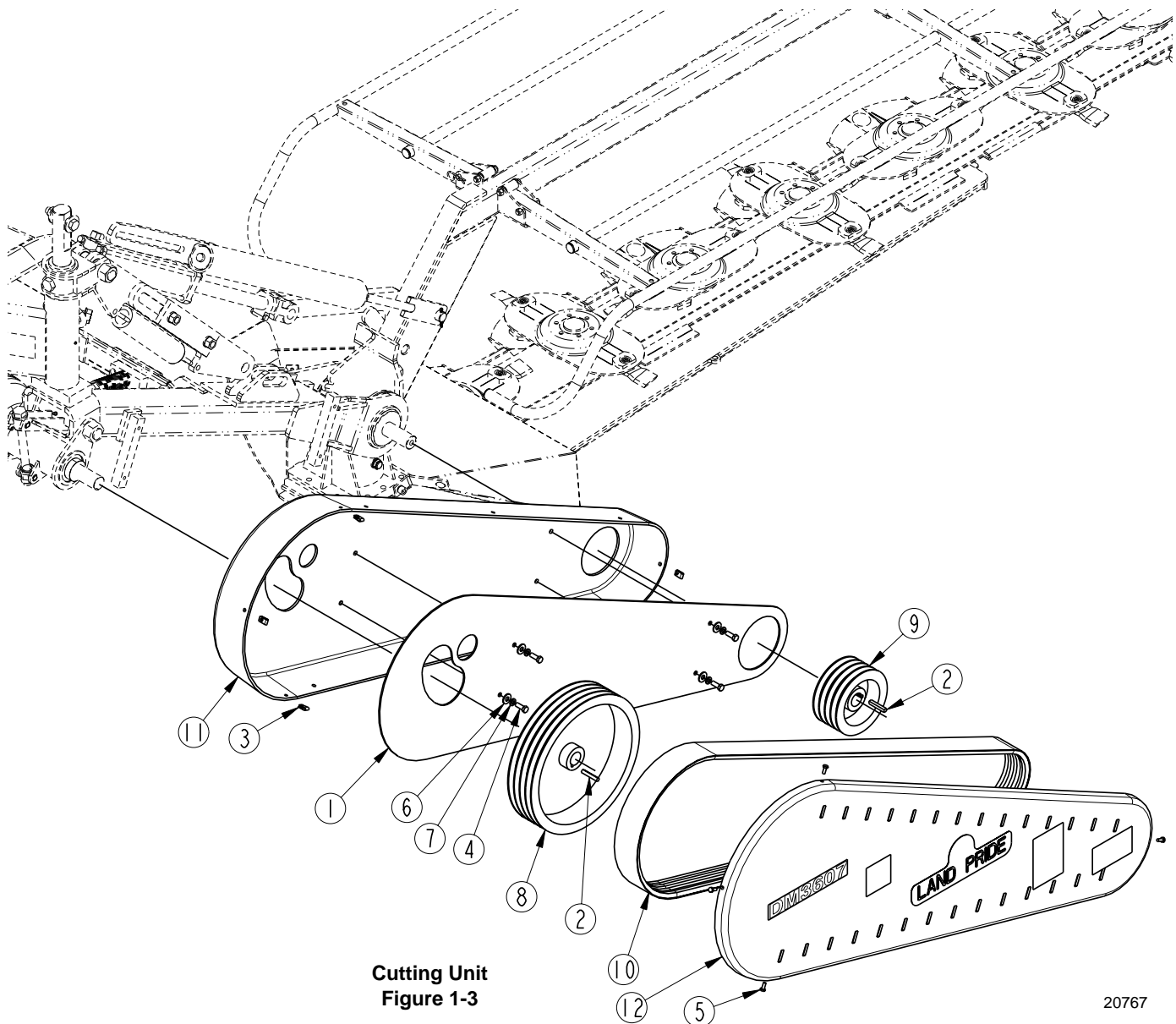

Cutting Unit
Figure 1-3

20767

Section 1 Assembly and Set-Up

Cutting Unit Assembly

Refer to Figure 1-5:

1. Install the support frame (#2) to the gearbox using the M16 bolts (#18) and lock washers (#29).
2. Assemble the blade bar support (#4) to the support frame (#2) using the 3/8" X 2 3/4" long bolts (#15) and lock nuts (#20).
3. Assemble the blade bar support (#4) to the cutting unit and secure with 1/2" X 1 1/2" bolt (#12), lock washer (#26) and nut (#21).
4. Attach shield brackets (#7), (#8) and (#9). Bracket (#7) is assembled with the longer socket head bolt. Bracket (#8) is assembled with a 1/2" X 1 1/4" long bolt (#16) and lock nut (#23). Bracket (#9) is assembled with the shorter socket head bolt (#17) and lock washer.
5. Assemble shield (#6) to brackets with carriage bolts (#14), washers (#24) and lock nut (#22).
6. Assemble the guide (#5) to the cutting unit with the 1/2" X 3 1/2" long bolt (#11), flat washer (#27) and lock nut (#23). Place the spring (#33) between the guide (#5) and flat washer (#27).
7. Assemble the front tarp frame (#1) and rear tarp frame (#3) to the support frame (#2) using 3/8" X 2 1/2" bolts (#13), lock washers, nuts (#20), pins (#32) and hair pin cotter pins (#31) to secure.
8. Position tarp over frame (#3) so the sewn end is towards the gearbox with cut out sliding down over (#2). Pull the other end of the tarp over the other end of the frame and slip the eyelets over the tarp frame ends. Fasten tarp to frame using cable ties (#34) and (#25).
9. Assemble bumpers (#10) to tarp frames with cotter pins (#30).

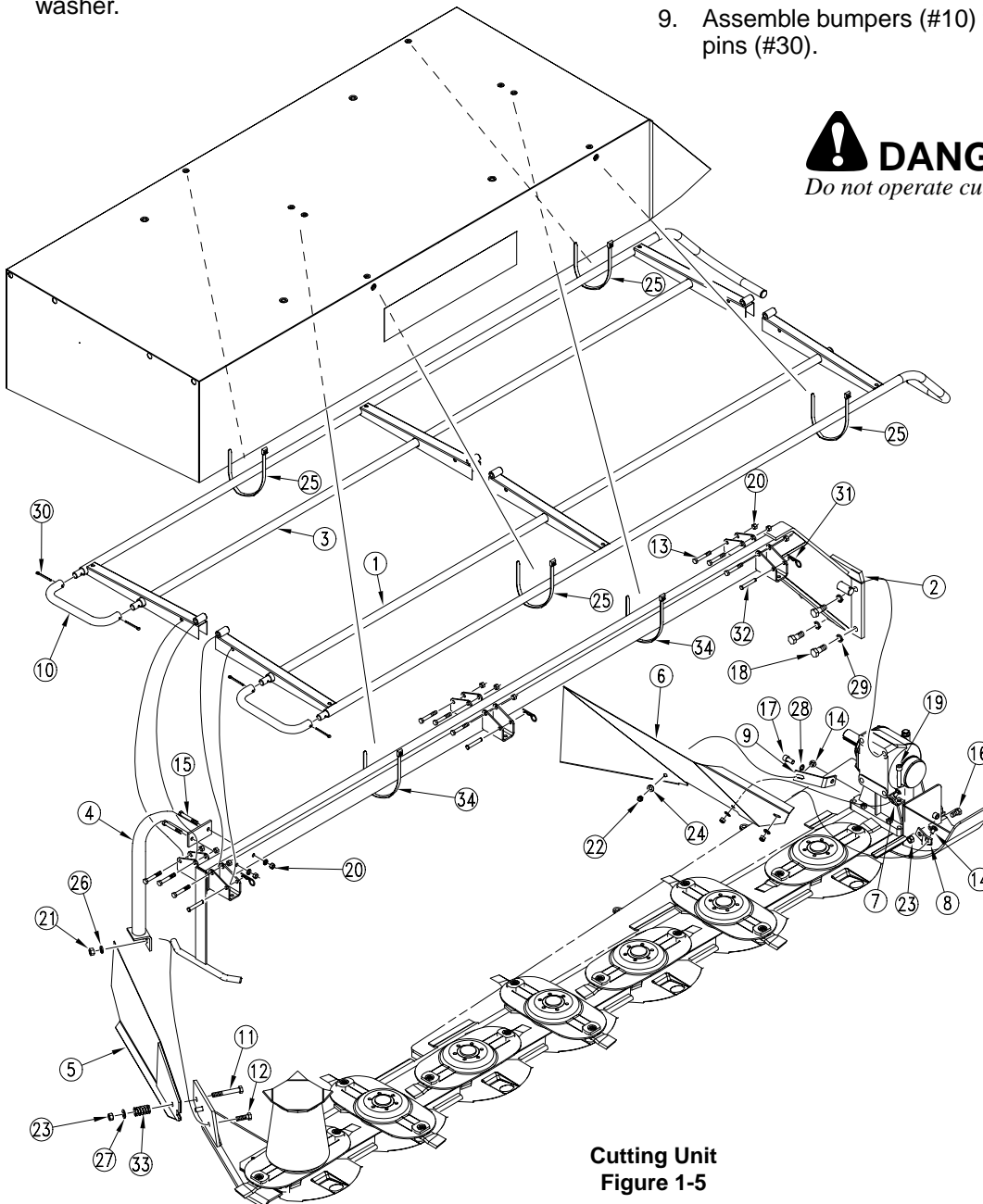

DANGER

Do not operate cutting unit without tarp in place!

Cutting Unit
Figure 1-5

20769

Section 2 Operating

Attaching the Tractor

1. Back the tractor up to the disc mower so that the lower draft arms are aligned with the lower lift pins of the disc mower. Connect 3-point upper link. Connect to lower 3-point arms with proper attaching hardware.
2. Raise 3 Pt until stroke control for 3 Pt disconnect becomes free. Move stroke control to storage position.
3. Raise the mower cutter bar off the ground slightly by actuating the hydraulic cylinder.
4. Adjust the length of the tractor's two sway link arms to prevent swaying from side to side.
5. Attach the chain to the top link of tractor making sure the PTO driveline is level.

6. If necessary use the adjustment on the lower 3-point arms of the tractor to make sure that the mower is level.
7. Raise the support leg and position it in the high position.
8. With the disc mower attached to the tractor, connect the PTO by twisting the collar on the end of the driveline while sliding on to the PTO shaft. Release collar and move yoke back and forth to make sure it is locked in place.

! WARNING

Be sure the driveline is properly connected. A loose yoke could slip and cause personal injury or damage to the mower.

Tractor Hook Up

First Three Point Offset

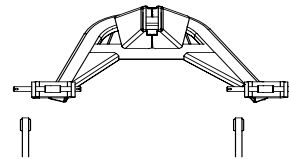

Second Three Point Offset And Quick Hitch Cat II

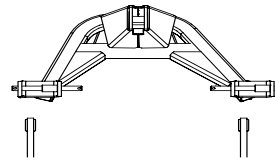

Third Three Point Offset

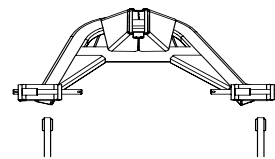

Fourth Three Point Offset

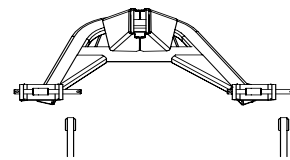

Spring Tension Adjustment for Spring Assembly:

With unit completely assembled and attached to a tractor, level 3 Pt arms on tractor, (make sure the stroke control is in the storage position). Retract the cylinder so that bar is in the vertical position. Tighten nut on the end of the spring rod (7 disc measure 3 1/2" approx. from end of rod to nut). Lower bar by lengthening cylinder to running position. Retract the cylinder and adjust tension as stated previously until cutter bar raises some what parallel to the ground. After several hours of run time this may need to be readjusted. Once the spring is adjusted, snug the jam nut.

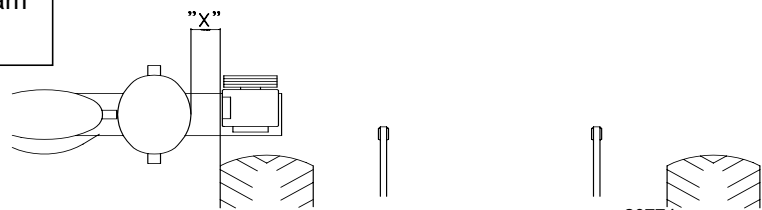

TRACTOR WHEEL ARRANGEMENT TO MOWER CUTTER BLADE. "X" DIMENSION SHOULD BE 4" OR MORE.

Section 2 Operating

Transporting



CAUTION

When traveling on public roads at night or during the day, use accessory lights and devices for adequate warning to operator's of other vehicles. Comply with all federal, state and local laws.

IMPORTANT: Always disengage the tractor's PTO before raising the mower to transport position.

NOTE: When raising the mower to the transport position be sure that PTO shaft does not contact tractor or mower.

1. Make sure stroke control for 3 Pt disconnect is in the storage position.
2. Raise the cutter bar so it is in a vertical position.
3. Make sure transport lock engages.
4. Make sure the support leg is in the high position.
5. Approach the disc mower from the rear making sure the Slow Moving Vehicle emblem of the tractor is visible to oncoming traffic.
6. Select a safe ground speed when transporting from one area to another. When traveling on roadways, transport in such a way that faster moving vehicles may pass you safely.
7. When traveling over rough or hilly terrain, shift tractor to a lower gear.

Operating Check List

In addition to design and configuration of equipment; hazard control and accident prevention are dependent upon the awareness, concern, prudence and proper training involved in their operation, transport, maintenance and storage of equipment. Before beginning to cut the following inspection should be performed.

Operating Checklist

✓	Check	Reference
	Safety Rules	Page 1
	Operating Instructions	This section
	Check oil level in gearbox and cutter bar.	Page 18
	Check that all plugs in gearbox have been replaced properly.	Page 18
	Be sure nuts and bolts are tight.	Page 26
	Be certain all guards and shields are in place.	Operator's Manual
	Lubricate mower as needed. Refer to "Maintenance and Lubrication."	Page 18
	Be sure all implement attaching points and hardware are secure and in place.	Operator's Manual
	Check for Hydraulic Leaks	Operator's Manual



DANGER

To avoid injury or death from entanglement in rotating drivelines, the drive gearbox shields must be in place and secure when operating.



DANGER

Do not operate mower without the curtain completely in place around the cutter bar. Do not lean against or stand on the curtain.

Section 2 Operating

Working Position

WARNING

Before lowering cutter bar, make sure no one is within 20 feet of mower.

1. Lower mower using the tractor lift.
2. Retract cylinder, pull rope to disengage transport latch.
3. Release the hydraulic cylinder and lower the cutter bar until it is parallel to the ground.
4. Raise 3-point so inner end of cutter bar is approximately 12" off the ground. Lower cutter bar hydraulic cylinder so outside end of bar is just touching the ground. Lower 3-point to work position.

NOTE: Before using the mower, check the break-away linkage to make sure all components work correctly.

Mowing Instructions

NOTE: Although the mower is shielded to prevent objects from being thrown by the blades, no one shield is 100% effective. As a rule most people are not knowledgeable of the dangers of being around a disc mower while it is in operation. Therefore, the operator should always stop mowing when someone passes by.

WARNING

Prolonged exposure to high sound levels require hearing protection. Wear hearing protection when operating this machine with open platform tractors.

Allow a few minutes for oil to spread in the cutter bar before engaging the PTO when changing from transport to operating position.

With the cutting bar on the ground, engage the PTO at low tractor idle and accelerate gradually to 540 rpm PTO speed.

If the cutter bar is operated at an angle for long periods of time, hold it horizontal for a few minutes every half hour or so of work to help lubricate gears at upper end of cutter bar.

Adapt forward speed to working conditions. Gear down when mowing in dense crops. Do not lower tractor rpm.

Adverse Field Conditions

DANGER

Do not use machine in rocky or stony conditions.

Extra care and precaution should be taken in rough or debris-ridden fields. The following adjustments should be made to the mower in these conditions to minimize the

possibility of foreign objects being deflected by the cutting blades.

1. Tilt the angle of the cutter bar back towards the horizontal position by lengthening top link to raise the cutting height of the knives.
2. Reduce the forward speed.
3. Make sure the cutting blades can pivot if an obstruction is hit.

IMPORTANT: If an obstruction is hit, idle engine, disengage PTO, shut off tractor, remove ignition key and wait for all moving parts to come to a complete stop. Inspect the entire mower and repair any damage before resuming operation.

CAUTION

Do not disengage PTO when engine is at full PTO rpm. Always idle engine before disengaging PTO.

IMPORTANT: To avoid personal injury, pick up all rocks and other debris before mowing. Never assume an area is clear, so enter a new area carefully. Cut material higher the first time to allow the mower to clear unseen objects.

The break-away latch allows the cutter bar to swing back if an obstruction is hit. If the latch releases, stop the tractor immediately, idle engine and disengage the PTO.

To reset the cutter bar, back the mower slowly and carefully until breakaway latch repositions. The factory setting of the latch is adapted to most working conditions.

Check the cutter bar for any damage before resuming operation.

If the cutter bar continues to break away after resetting, the pressure of the spring assembly can be increased. In all cases the length must not be less than 3 3/4" to 3 7/8" or safety disengagement cannot function.

The stack of spring washers should be compressed to 3 3/4" to 3 7/8". See Figure 3-1.

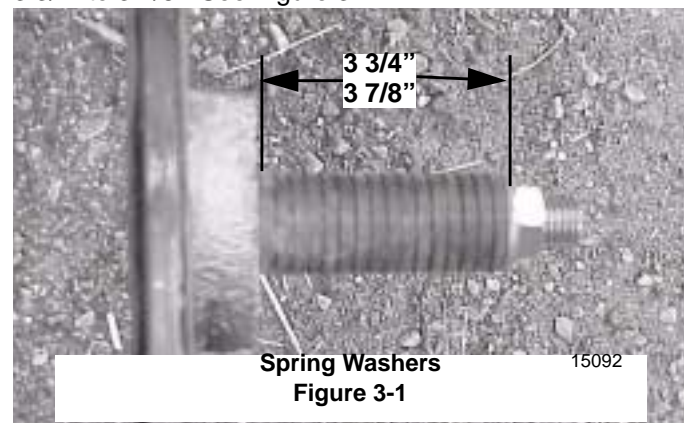

Spring Washers
Figure 3-1

15092

Section 2 Operating

Operating Instructions

By now you should have thoroughly read your Disc Mower Operator's Manual, properly attached your Land Pride Disc Mower to your tractor, and reviewed the Operating Checklist. If you have not yet completed all of these functions, please do so now.

Now that you're properly briefed and your Disc Mower is ready, it's time to transport to the field.

For transport purposes, your Disc Mower should be securely locked with the cutter bar in the upright or vertical position. Make sure the support leg is in the high position. A "Slow Moving Vehicle" sign should be in place and visible from the rear, if you are using a public road or right-of-way. Select a safe speed and transport to your cutting site in such manner that faster moving vehicles can pass you safely.

Once you have safely arrived at your field, position your tractor on level ground. Make sure that no one is within 20 ft of the mower, as you prepare to lower the cutter bar from transport to working position. Lower the three-point hitch to a point where the inboard end of the cutter bar is approximately 12" off of the ground. Retract your lift cylinder and pull on the latch cord to release the transport or road-latch mechanism. Using your lift cylinder control lever, slowly lower the cutter bar until the outer end touches the ground. Adjust the three-point hitch to "working position" where the driveline is horizontal with the ground and lock the three-point hitch control lever in place. Extend the lift cylinder until there is 1" of clearance over the reach arm. Your Disc Mower is now in working position.

Controlling or setting your cutting height is accomplished by adjusting the "top link" on your three-point hitch. Extending or lengthening the top link will raise your cutting height, while shortening the top link will lower the cutting height. If you are cutting in an area you are not familiar with or believe there might be rocks or debris present, you must raise the cutting height accordingly. This will reduce the potential of personal injury and or damage to the machine. Shut the mower down immediately if someone approaches in a vehicle or on foot.

If you do hit an object when you are mowing, immediately disengage the PTO, idle the engine, stop the tractor, wait for all moving parts to come to a complete stop, shut off the tractor, set the brake, remove the keys, and inspect for damage. If damage is present, make the necessary repairs. If no damage is present, but you have tripped the Break Away Safety Latch, slowly reverse the tractor until the latch resets and proceed with mowing operations.

Prior to actually beginning cutting operations, you will want to get the mower up to full 540 rpm PTO speed by engaging the PTO with the tractor engine at idle and gradually increasing engine rpm to PTO speed. Once you reach the full 540 rpm, allow the mower to run for a few minutes at level position so the oil in the cutter bar can lubricate all internal moving parts. You will also want to take this opportunity to make a quick Operational Running Check. Listen and visually inspect for any component or part that may be loose or out of adjustment. Don't be alarmed by the noise level of the free running Disc Mower. It will actually become quieter when you begin mowing and have some run in time on it.

If your Operational Running Check was ok, begin mowing operations by opening up the lands on your field. Make enough lands so you can easily make your turns to properly line up for each pass down the field. If your tractor and Disc Mower are set up right, you should be able to straddle the previous swath as you make each subsequent pass starting in the center of the field. If you do experience cutting problems, refer to the "Trouble Shooting" section of the Operator's Manual for corrective action.

When you are done mowing for the day and need to transport the mower to your storage site, simply reverse the process you used to take the mower out of transport mode. When you are done mowing for the season, clean and lubricate your mower, replace worn or missing parts, release tension on the belts, install the stroke control to the tarp frame cushion spring rod and store the unit with the cutter bar in the horizontal working position. You will get longer service life out of your mower by storing it inside and repainting scratched or rusted components.

With a little practice and experience you should become very good at operating your Land Pride Disc Mower.

Section 3 Adjustments

! DANGER

Before making any adjustments to this machine, disengage PTO, shut off tractor, remove ignition key and wait for all moving parts to stop. Disconnect the PTO driveline.

Transport Lock Operation

The transport lock is designed so that the operator does not need to get off the tractor from field operation retract the hydraulic cylinder until lock engages. From transport position pull rope and extend the cylinder until bar reaches field run position.

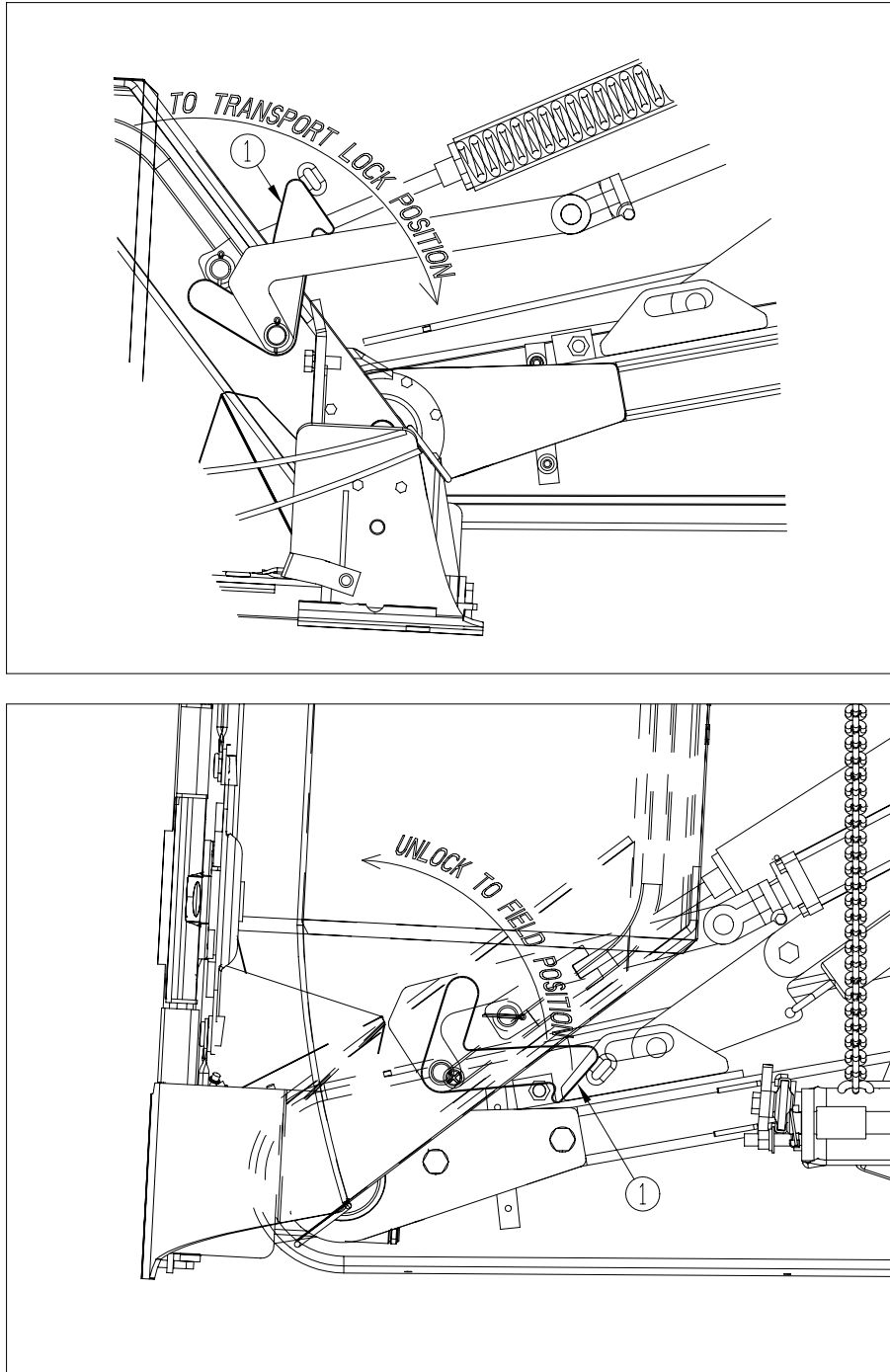

**Transport Lock
Figure 2-1**

20773

Section 3 Adjustments

Belt Tension Adjustment

Belt must be properly tensioned at all times to avoid excessive flopping and slipping. Loose belt will also cause poor cutting and premature wear.

Check tightness of the belt regularly, especially when working the first few hours.

Always retighten or check belt after 4-8 hours of operation.

Refer to Figure 2-2.

1. Loosen main pivot bolt.
2. Tighten nut on the belt tension bolt until you have a 3/4" deflection midpoint between pulleys. Tighten main pivot bolt. Refer to Figure 2-3.

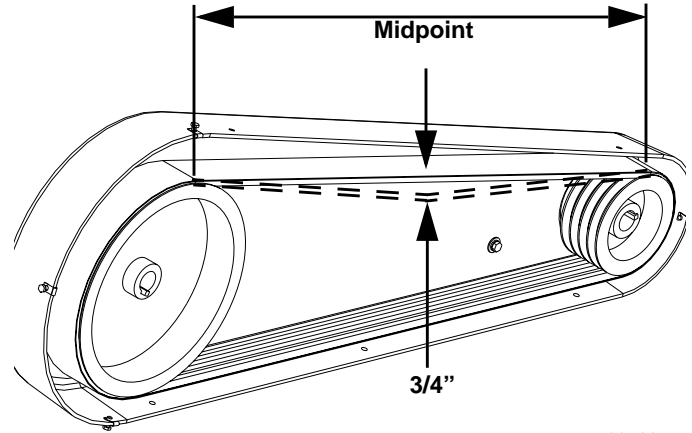
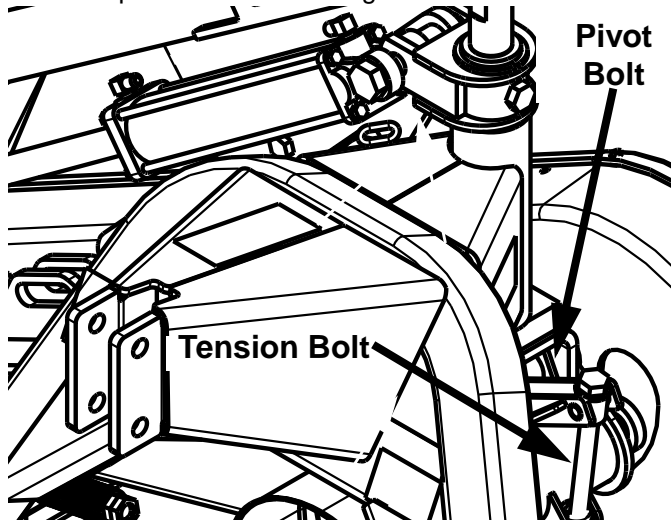

Belt Deflection
Figure 2-3

20766

Belt Tension Adjustment
Figure 2-2

20762

Cutting Height

Refer to Figure 2-4:

Cutting height can be adjusted with the upper 3-point hitch link.

Maximum cutting height of 2 3/8" is achieved when the discs are parallel to the ground. Adjustment of cutting height is achieved by altering the cutter bar tilt angle. This

is done by varying the upper 3-point hitch link length until desired cutting height is achieved. Shorten the upper 3-point hitch link to lower and lengthen to raise.

To minimize blade and disc wear, improve grass regrowth and get maximum nutritive value from the crop, minimum cutting height should never be adjusted less than 1 1/4".

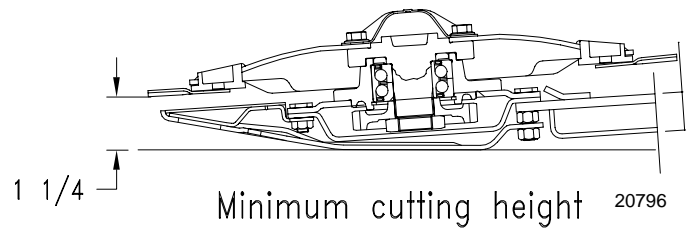
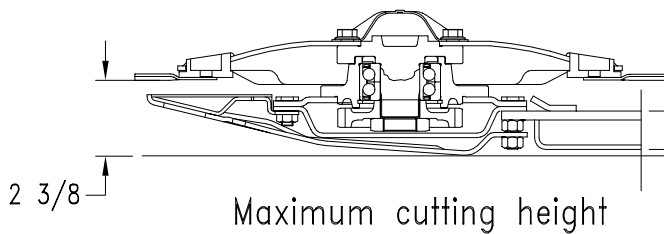

Cutting Height
Figure 2-4

20796

Section 4 Maintenance and Lubrication

General Maintenance

Proper servicing and adjustment is the key to the long life of any farm implement. With careful and systematic inspection, you can avoid costly maintenance, time and repair.

! DANGER

Before servicing this machine, turn off the tractor engine, remove the ignition key and disconnect the PTO driveline.

Each new machine should be checked after the first 10 hours of work. All screws and bolt torques should be routinely checked.

At the beginning of each season

1. Check and/or change the oil; lubricate or grease all points. See *Lubrication* in this section.
2. Check blade wear and condition of their fasteners, see “**Servicing Blades**”, page 18.
3. Check wear on guards and curtain.
4. Retention belts, see “**Belt Tension Adjustment**”, page 17.
5. Check all screws and bolts to be sure they are tight.

Servicing Blades

Cutting quality as well as safe operation depend on the regular inspection and care given to the knives.

! WARNING

To avoid personal injury when the blades and/or carrier are being serviced, always block the mower up to prevent it from falling.

Check blades for cracks and wear and blade bolts for tightness daily. Blades should be replaced when they are worn excessively, bent, nicked, deformed, or out of balance.

NOTE: Blade bolts should be tightened to 55 ft-lb torque.

NOTE: Always replace damaged blades. Never straighten a bent blade. Never replace one knife only per disc. Always replace both of them to avoid creating an out-of-balance force.

! CAUTION

Replace with Land Pride blades only. Substitute blades may not meet specifications and may fail in a hazardous manner that could cause injury.

! CAUTION

When changing blades, always replace the blade bolt & blade nut together at the same time. Worn or damaged blade bolts or nuts could fail in a hazardous manner that could cause injury.

Blade Replacement

Refer to Figure 4-1:

1. New blades are 1.85” wide. Blades should be replaced when they are worn to about 1 5/16” (B) wide at a distance of 3/8” from the disc. The length (A) of the blade should be greater than 2 1/2”.
2. Replace blades if the hole for the securing bolt has become oval 3/32” more than the diameter of the original hole.

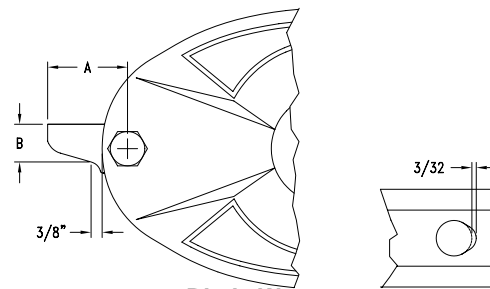

15093 **Blade Wear**
Figure 4-1

3. Blades are reversible.

Fastener Replacement

NOTE: Always replace blade bolts and nuts when they have been removed 5 times.

1. Replace fasteners when a visible deformation is found.
2. Replace bolts when wear on the bolt head reaches the contact area of the blade.
3. Replace bolts when the flat sides at the bolt flange are excessively worn or missing altogether.

Refer to Figure 4-2:

4. Replace bolts when the diameter (D) of the bolt shoulder is less than 5/8”.
5. Replace nuts when the height (H) of the nut is less than half of the original height of 3/8”.
6. Replace Belleville washers on breakaway if they are flattened.

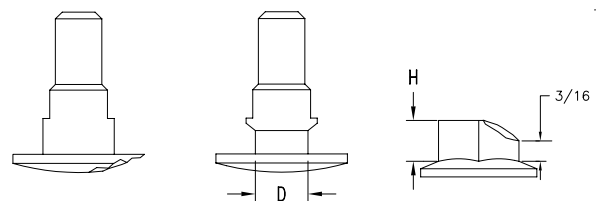

20798 **Fastener Wear**
Figure 4-2

Section 4 Maintenance and Lubrication

Cutter Bar Timing Adjustment

Removal of disc shaft assemblies

Refer to Figure 4-3:

1. Rotate the long axis of the discs adjacent to the replaced shaft assembly 90 degrees to the long axis of the cutter bar.
2. Line up the new gear's mounting holes with holes in the cutter bar. Rotate gear so that the axis of two of the disc mounting holes are 90 degrees to the long axis of the cutting bar (figure 4-3). Try sliding gear into place. This step may need to be repeated, using the next pair of holes until the gear will slide into place. Apply sealant between gear assembly housing and cutter bar then bolt housing into place.
3. When gear is lined up correctly, the disc will now mount to the gear with its long axis parallel to the long axis of the cutter bar (90 degrees to the axis of the adjacent discs).

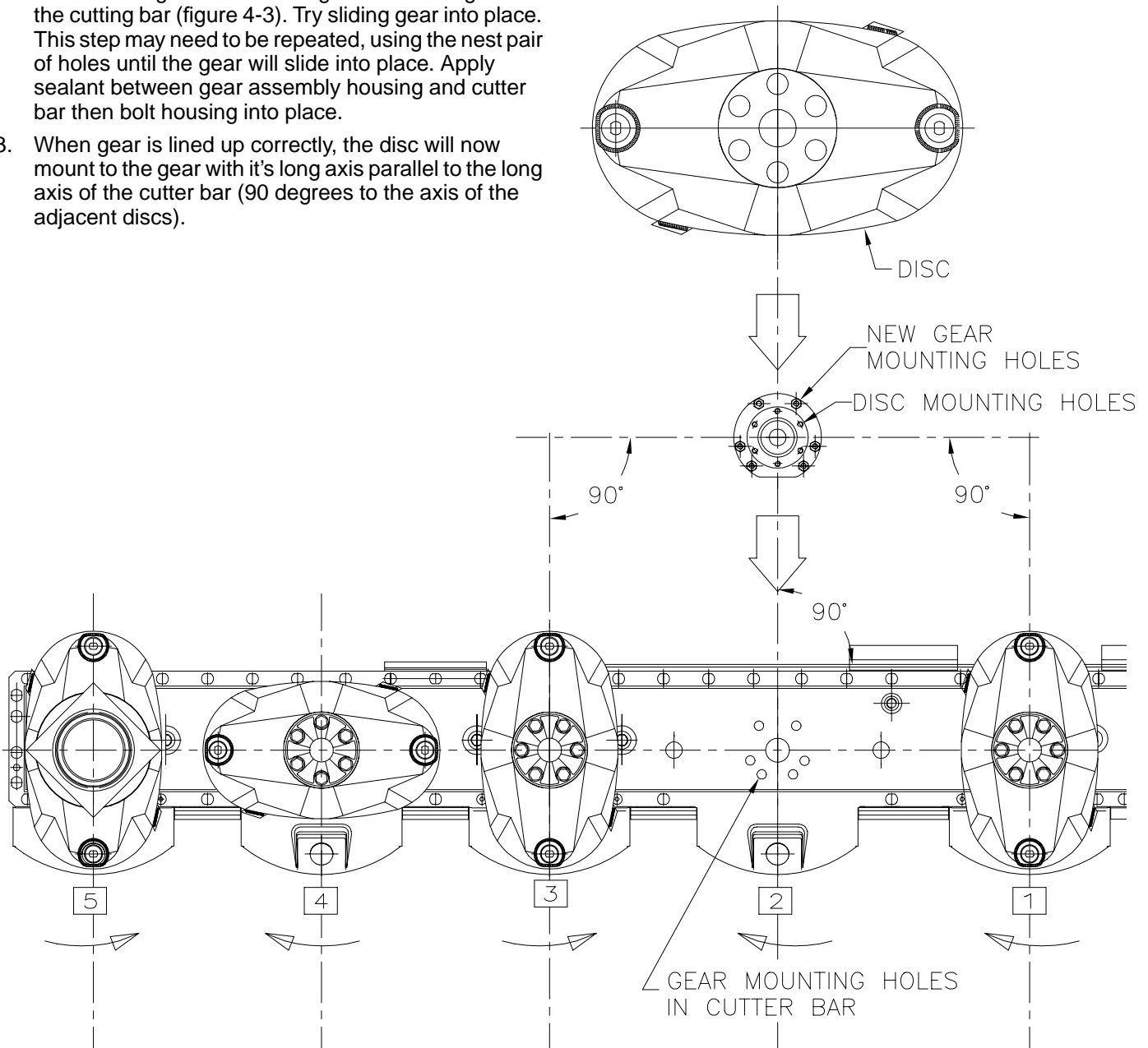

Disc Assembly
Figure 4-3

Section 4 Maintenance and Lubrication





Storage

At the end of the working season or when the mower will not be used for a long period, it is good practice to clean off any dirt or grease that may have accumulated on the mower and any of the moving parts.



1. Clean the Disc Mower as necessary.
2. Check the blades and blade fasteners for wear and replace if necessary, see “**Servicing Blades**”, Page 18.
3. Inspect the mower for loose, damaged or worn parts and adjust or replace as needed.
4. Lubricate as noted in “**Section 4 Maintenance and Lubrication**” on page 18.
5. Release tension on drive belts.
6. Move stroke control to disconnect position.
7. Store cutter bar in horizontal (operating) position.
8. Store the Disc Mower inside if possible for longer Disc Mower life.
9. Repaint parts where paint is worn or scratched to prevent rust.

Section 4 Maintenance and Lubrication

Lubrication

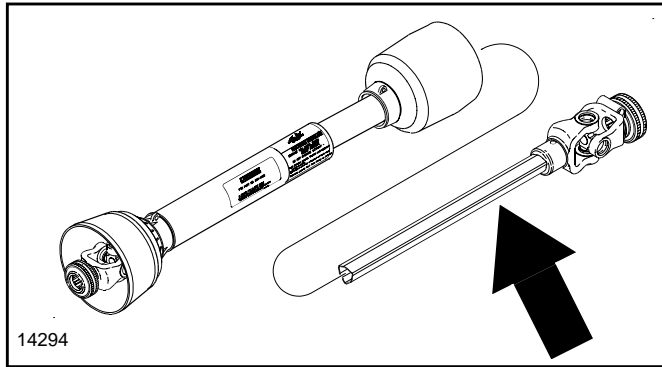
Lubrication Legend	 Multi-purpose spray lube	 Multi-purpose grease lube	 Multi-purpose oil lube	 Intervals at which lubrication is required





	
---	---

Driveline

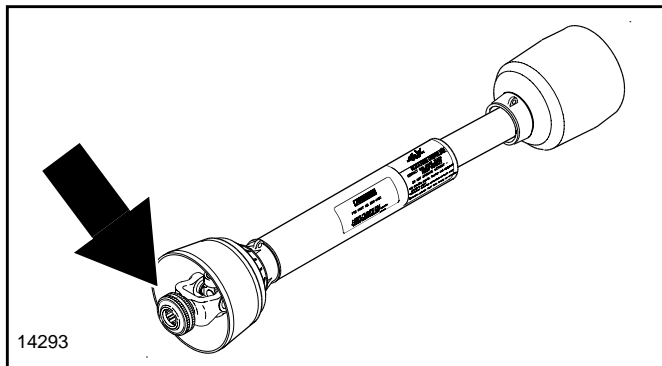
Quantity = Clean & coat the inner tube of the driveline with a light film of grease and then reassemble.



	
--	--

Driveline U-Joints

Type of Lubrication: Grease

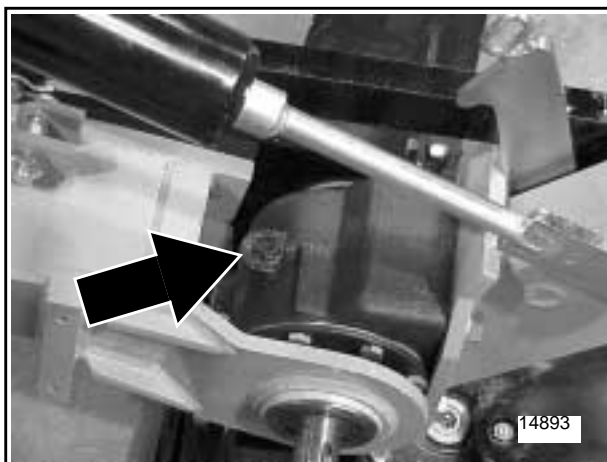

	
---	---

Gearbox

Check oil level in the gearbox by removing the vent plug and checking the dipstick. If the level is below line on the dipstick, add oil.

NOTE: Do not overfill. Mower should be level when checking oil.

Type of Lubrication: SAE 90 GL4 (EP) gear lube

Quantity = fill until level with line on the dipstick

Section 4 Maintenance and Lubrication

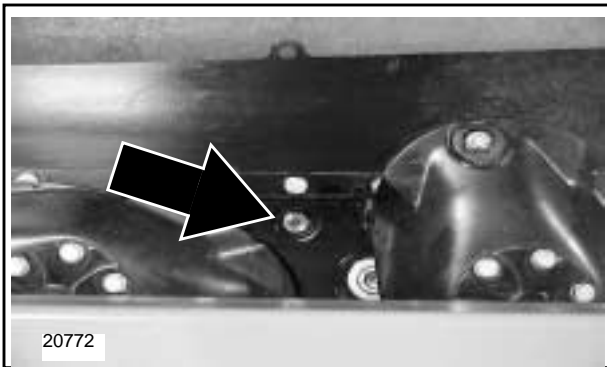

Cutter Bar

Check oil level in the cutter bar by removing the filler level plug with cutter bar in transport position. (The plug is located between the first and second discs on the DM3605 and between the second and third discs on DM3606 and between the second and third discs on DM3607.) If the oil level is low, add oil.

NOTE: Do not overfill. Mower should be level and cutter bar vertical when checking oil. Be sure to let cutting bar set in vertical position for a few minutes before checking to allow time for oil to flow to the bottom of bar.

Type of Lubrication: SAE 90 GL4 (EP) gear lube
Quantity =fill until level with in filler level plug hole.

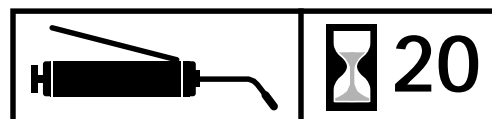
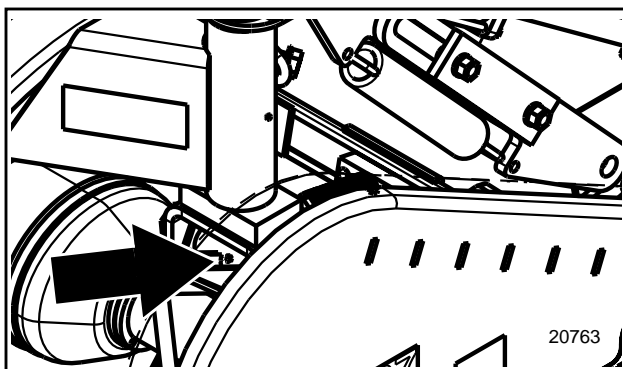

Frame Pivot Point

Type of Lubrication: Grease

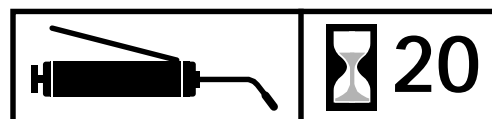
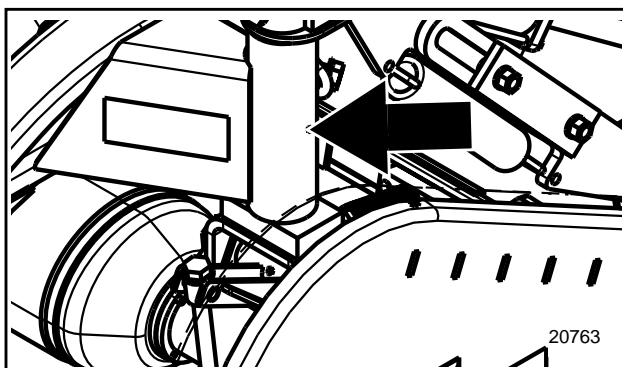

Hitch Pivot Point

Type of Lubrication: Grease

Section 5 Specifications and Capacities

DM36 Series Disc Mowers			
	DM3605	DM3606	DM3607
Number of Discs	5	6	7
Cutting Width	6' 9"	8' 0"	9' 4"
Transport Width	74"	74"	74"
Recommended Tractor PTO HP Range	35 - 80 HP		
PTO speed	540 RPM		
Disc tip speed	15,764 FPM		
Weight (approximate)	1045 lbs.	1090 lbs.	1135 lbs.
Gearbox Ratio	2.06		
Gearbox Oil capacity	1.48 pints		
Cutter Bar Oil capacity	5.92 pints	6.55 pints	7.4 pints

Section 6 Features and Benefits

DM36 Series Disc Mowers	
Features	Benefits
Cutter bar 82", 96" and 112" widths	5, 6 and 7 Disc models available.
Common oil chamber	Gears splash oil from gear to gear.
Warranty	2 Year, 1 Year on driveline.
Cutting angle	15 Degrees down and 20 degrees up.
Narrow transport	74" - usually not much wider than tire distance, safer in transport.
Hook-ups	Three types of hook-ups. Cat. 2, Cat. 3 and Quick-Hitch Cat. 2.
Rock Guards	Replaceable.
Hydraulic cutterbar lift	Quickly raise for obstructions.
Cutterbar Drive	Gear
0" Minimum cutting height	Run skid shoes on ground to mow very short.
Gates power drive belt	Stronger than multiple belt system.
2 Hardened blades per disc, reversible	Reversible blades give double life, hardened for longevity against debris.
3" Blade overlap	Eliminates skipping for a cleaner cut.
High blade tip speed	15,764 fpm, offers a nice clean cut.
Storage stand	Aids in storage and in hooking to tractor.
Skid shoes	Easily replaceable when worn out.

Section 7 Troubleshooting

Problem	Cause	Solution
Not cutting clean	Dull Blades.	Replace blades.
	Mower not level.	Adjust machine.
	Ground speed too fast.	Reduce ground speed.
	Blades locked back.	Free blades.
Streaking conditions in swath	Conditions too wet for cutting.	Allow grass to dry before cutting. Slow ground speed of tractor but keep engine running at full PTO rpm.
	Dull blades.	Sharpen or replace blades.
	Wet mud build-up between skid shoes	Clean area between skids. Raise cutting height.
Gearbox noisy	Rough gears.	Run in or gear failure.
	Worn bearing.	Replace bearing.
Gearbox leaking	Damaged oil seal.	Replace seal.
	Bent shaft.	Replace oil seal and shaft.
	Oil seal not sealing in the housing.	Replace seal or use a sealant on OD of seal.
	Oil level too high.	Drain oil to proper level.
	Gasket damaged.	Replace gasket.
	Bolts loose.	Tighten bolts.
Uneven stubble	Too much tilt on cutter bar.	Reduce tilt.
	Low PTO speed.	Increase engine speed to run PTO at 540 rpm.
	Blades not installed correctly.	Make sure that the arrow on the knife upper face is pointing in the direction of rotation of the disc.
	Low disc speed.	Check belt for correct tension.
	Dull or broken blades.	Replace blades.
Stubble too long	Incorrect angle on cutter bar.	Change cutter bar angle using tractor top link.
	Insufficient cutter bar down pressure.	Adjust compensating spring tension.
Soil built up in front of cutter bar	Very wet conditions	Adjust main frame height by shortening safety chain as necessary.
	Too much cutter bar down pressure	Adjust compensating spring tension.
Machine breaking back too easily	Insufficient tension on break-away spring washers.	Tighten break-away spring.

Section 8 Appendix

Torque Values Chart for Common Bolt Sizes

Bolt Size (Inches) in-tip ¹	Bolt Head Identification						Bolt Size (Metric) mm x pitch ⁴	Bolt Head Identification					
	Grade 2		Grade 5		Grade 8			5.8		8.8		10.9	
	N · m ²	ft-lb ³	N · m	ft-lb	N · m	ft-lb		N · m	ft-lb	N · m	ft-lb	N · m	ft-lb
1/4" - 20	7.4	5.6	11	8	16	12	M 5 X 0.8	4	3	6	5	9	7
1/4" - 28	8.5	6	13	10	18	14	M 6 X 1	7	5	11	8	15	11
5/16" - 18	15	11	24	17	33	25	M 8 X 1.25	17	12	26	19	36	27
5/16" - 24	17	13	26	19	37	27	M 8 X 1	18	13	28	21	39	29
3/8" - 16	27	20	42	31	59	44	M10 X 1.5	33	24	52	39	72	53
3/8" - 24	31	22	47	35	67	49	M10 X 0.75	39	29	61	45	85	62
7/16" - 14	43	32	67	49	95	70	M12 X 1.75	58	42	91	67	125	93
7/16" - 20	49	36	75	55	105	78	M12 X 1.5	60	44	95	70	130	97
1/2" - 13	66	49	105	76	145	105	M12 X 1	90	66	105	77	145	105
1/2" - 20	75	55	115	85	165	120	M14 X 2	92	68	145	105	200	150
9/16" - 12	95	70	150	110	210	155	M14 X 1.5	99	73	155	115	215	160
9/16" - 18	105	79	165	120	235	170	M16 X 2	145	105	225	165	315	230
5/8" - 11	130	97	205	150	285	210	M16 X 1.5	155	115	240	180	335	245
5/8" - 18	150	110	230	170	325	240	M18 X 2.5	195	145	310	230	405	300
3/4" - 10	235	170	360	265	510	375	M18 X 1.5	220	165	350	260	485	355
3/4" - 16	260	190	405	295	570	420	M20 X 2.5	280	205	440	325	610	450
7/8" - 9	225	165	585	430	820	605	M20 X 1.5	310	230	650	480	900	665
7/8" - 14	250	185	640	475	905	670	M24 X 3	480	355	760	560	1050	780
1" - 8	340	250	875	645	1230	910	M24 X 2	525	390	830	610	1150	845
1" - 12	370	275	955	705	1350	995	M30 X 3.5	960	705	1510	1120	2100	1550
1-1/8" - 7	480	355	1080	795	1750	1290	M30 X 2	1060	785	1680	1240	2320	1710
1 1/8" - 12	540	395	1210	890	1960	1440	M36 X 3.5	1730	1270	2650	1950	3660	2700
1 1/4" - 7	680	500	1520	1120	2460	1820	M36 X 2	1880	1380	2960	2190	4100	3220
1 1/4" - 12	750	555	1680	1240	2730	2010							
1 3/8" - 6	890	655	1990	1470	3230	2380							
1 3/8" - 12	1010	745	2270	1670	3680	2710							
1 1/2" - 6	1180	870	2640	1950	4290	3160							
1 1/2" - 12	1330	980	2970	2190	4820	3560							

¹ in-tip = nominal thread dia. in inches-threads per inch

² N · m = newton-meters

³ ft-lb = foot pounds

⁴ mm x pitch = nominal thread dia. in millimeters x thread pitch

Torque tolerance + 0%, -15% of torquing values. Unless otherwise specified use torque values listed above.

Warranty

Land Pride warrants to the original purchaser that this Land Pride product will be free from defects in material and workmanship beginning on the date of purchase by the end user according to the following schedule when used as intended and under normal service and conditions for personal use.

Overall Unit: 2 Year Parts and Labor

Gearbox: 2 Year Parts and Labor

Driveline: 1 Year Parts and Labor

Blades and belt considered wear items

This Warranty is limited to the replacement of any defective part by Land Pride and the installation by the dealer of any such replacement part, and does not cover common wear items such as blades, belts, tines, etc. Land Pride reserves the right to inspect any equipment or parts which are claimed to have been defective in material or workmanship.

This Warranty does not apply to any part or product which in Land Pride's judgment shall have been misused or damaged by accident or lack of normal maintenance or care, or which has been repaired or altered in a way which adversely affects its performance or reliability, or which has been used for a purpose for which the product is not designed. Misuse also specifically includes failure to properly maintain oil levels, grease points, and driveline shafts.

Claims under this Warranty must be made to the dealer which originally sold the product and all warranty adjustments must be made through such dealer. Land Pride reserves the right to make changes in materials or design of the product at any time without notice.

This Warranty shall not be interpreted to render Land Pride liable for damages of any kind, direct, consequential, or contingent to property. Furthermore, Land Pride shall not be liable for damages resulting from any cause beyond its reasonable control. This Warranty does not extend to loss of crops, any expense or loss for labor, supplies, rental machinery or for any other reason.

No other warranty of any kind whatsoever, expressed or implied, is made with respect to this sale; and all implied warranties of merchantability and fitness for a particular purpose which exceed the obligations set forth in this written warranty are hereby disclaimed and excluded from this sale.

This Warranty is not valid unless registered with Land Pride within 30 days from the date of purchase by the end user.



Corporate Office: P.O. Box 5060
Salina, Kansas 67402-5060 USA
www.landpride.com
